

Session Objectives: 1. Introduce: Backhand Shot, Starting with the Puck  
2. Review: ABC's, Forehand Shot, Skating with the Puck, Stationary Stickhandling

## 10 MIN

## WARM-UP

## WARM UP (1.1.07/1.1.04/1.4.03/1.3.06)

Skate clockwise direction; between blue lines glide on one foot, jump the lines on one foot, c-cuts - both feet, stop 'n go on red line (always facing same side of rink). Add pucks if desired.

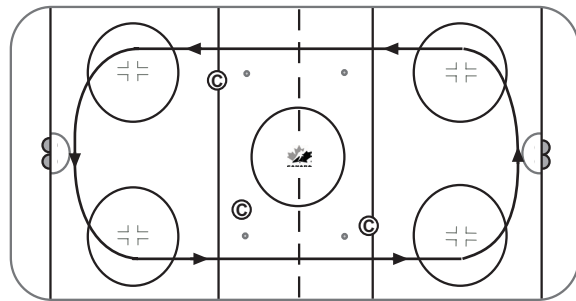

## 20 MIN

## SKILL STATIONS #1

## 1. BACKHAND SHOT (3.1.02)

Review and demonstrate key points. Players spread out around the boards. Players stand stationary 3-4 meters from boards. Go through movements of shooting without puck. Add pucks. Shoot for a spot on the boards.

## 2. SCATTER PUCK

Divide into two teams. Paint dividing line down middle of ice. Give each team equal number of pucks. On signal, players shoot their pucks to other side of the ice and continue gathering and shooting until whistle. Players may not cross the line. Team with fewest pucks on their side wins. Even up the pucks and play again.

## 3. STARTING WITH THE PUCK

Each player with a puck. Move puck left to right in front of body. Repeat but players call out number of fingers instructor is holding up. Move puck on side from front to back. Players skate forward at easy pace and stickhandle but limiting side travel of puck. Review and demonstrate starting with a puck - push the puck slightly ahead of you. Skate out to it and perform stickhandle while crossing the zone. Players cross zone in wave formation. If too many players use 2 waves. If time allows play game of "red light - green light" with players carrying puck. Should use proper method of starting with the puck.

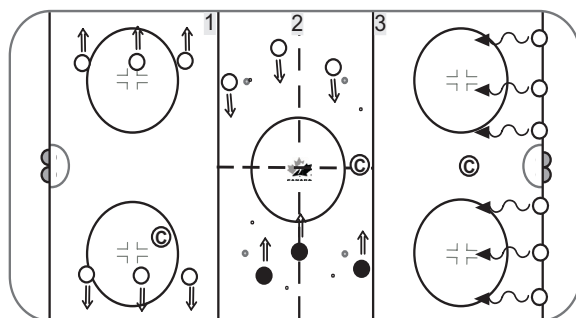

## 20 MIN

## SKILL STATIONS #2

## 1. INSIDE OUT

Each player takes a puck and stickhandles anywhere inside blue line. Coach says "Inside," players must stickhandle inside one of the 2 face-off circles. Coach says "Out," players must stickhandle anywhere inside blue line except the face-off circles. Repeat several times encouraging players to move quickly, stickhandling in the confined space and look up frequently to avoid collisions.

## 2. GLIDING WITH KNEE BEND (1.1.09)

Review and demonstrate key points. Players line up on boards. Player takes a few strides to gain momentum then glides on one foot. Once gliding on one foot, add a deep knee bend. Player holds knee bend for 1-2 seconds then rises, and repeats. Repeat with other foot.

## 3. STATIONARY PUCK CONTROL (2.1.02/2.1.03/2.1.04)

Line players up in stickhandling position with a puck in front of them. Have players move puck in front of body narrow, wide, and then narrow-wide combination. Continue while players shout out number of fingers held up by instructor (players will have to look up).

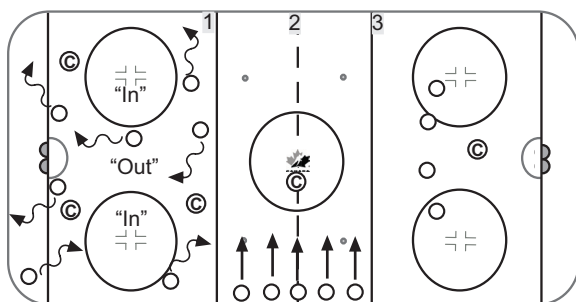

## 10 MIN

## FUN GAME

## TOILET BOWL TAG

Players play without sticks. Players must skate around end zone with hands on their knees. Coaches are "it" and must tag players. Tagged players must stand still with their arm straight out (flusher). To be freed, another player must skate under the flusher, stop and push arm down (flush the toilet).

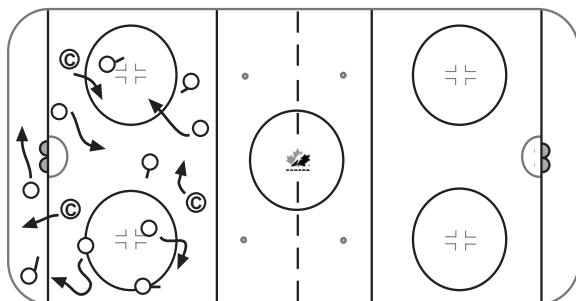

Do not forget to incorporate the Warm-up session prior to introducing your skill stations and the fun game at the end of your practice from the previous page.

Additional ice stations: You may choose either Option 1: Skill Stations #1 plus Skill Skations #2, Option 2: Skills Stations #2 repeated 3 times or Option 3: Skill Stations #3 only

**SKILL STATIONS #1 - 4 STATION SETUP**

- 1. BACKHAND SHOT (3.1.02)
- 2. STARTING WITH THE PUCK
- 3. GLIDING WITH KNEE BEND (1.1.09)
- 4. STATIONARY PUCK CONTROL (2.1.02/2.1.03/2.1.04)

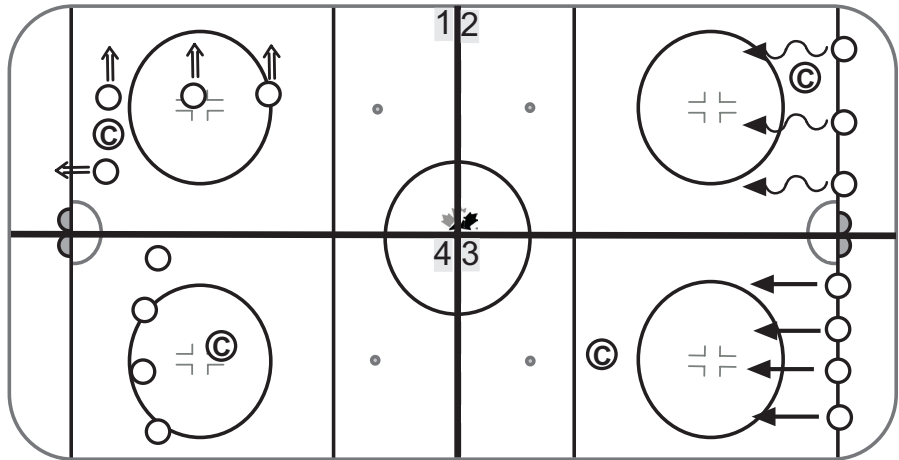

**SKILL STATIONS #2 - 2 STATION SETUP**

- 1. INSIDE OUT
- 2. SCATTER PUCK

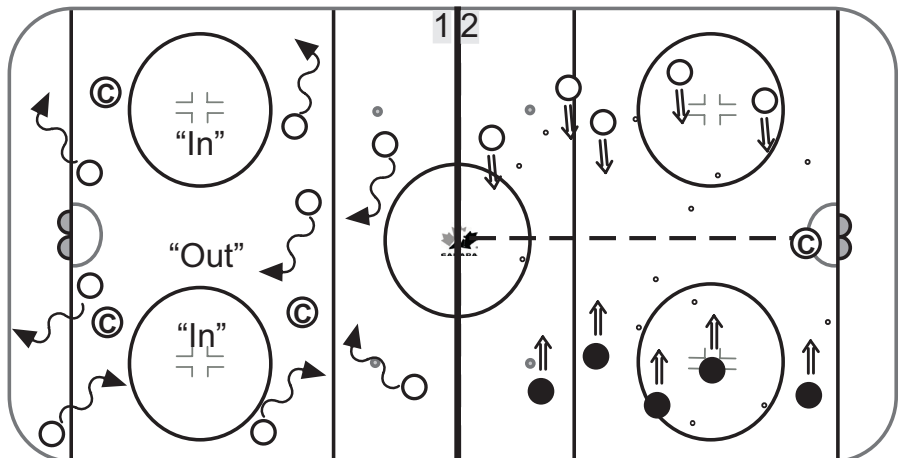

**SKILL STATIONS #3 - 6 STATION SETUP**

- 1. BACKHAND SHOT (3.1.02)
- 2. SCATTER PUCK
- 3. STARTING WITH THE PUCK
- 4. INSIDE OUT
- 5. GLIDING WITH KNEE BEND (1.1.09)
- 6. STATIONARY PUCK CONTROL (2.1.02/2.1.03/2.1.04)

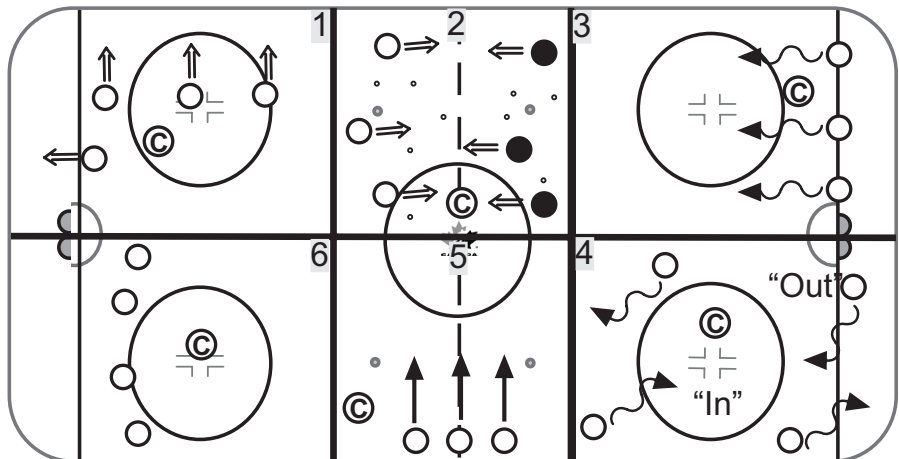

Session Objectives: Review: ABC's, Forehand & Backhand Shot, Stationary Stickhandling

## 10 MIN

## WARM-UP

**WARM UP (1.1.07/1.4.03/1.3.06)**

Skate clockwise direction; between blue lines glide on one foot, jump the lines on one foot, c-cuts - both feet, stop 'n go on red line (always facing same side of rink). Add pucks if desired.

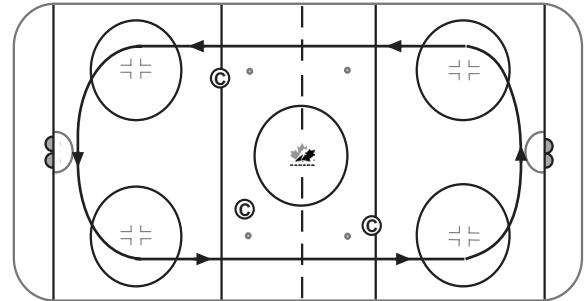

## 20 MIN

## SKILL STATIONS #1

**1. FOREHAND AND BACKHAND SHOT (3.1.01/3.1.02)**

Review and demonstrate key points of forehand shot. Players spread out around the boards and stand stationary 3-4 meters from boards. Shoot for a spot on the boards. Coaches provide feedback. Repeat with backhand shot.

**2. STATIONARY STICKHANDLING (2.1.02/2.1.03/2.1.04)**

Line players up in stickhandling position with a puck in front of them. Have players move puck in front of body narrow, wide, then narrow-wide combination. Continue while players shout out number of fingers held up by instructor (players will have to look up).

**3. SCATTER PUCK**

Divide into two teams. Paint dividing line down middle of ice. Give each team equal number of pucks. On signal, players shoot their pucks to other side of the ice and continue gathering and shooting until whistle. Players may not cross the line. Team with fewest pucks on their side wins. Even up the pucks and play again. Repeat with backhand shots only.

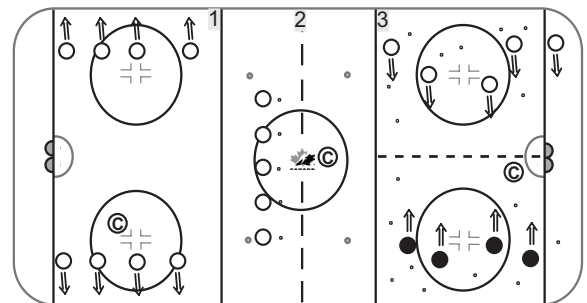

## 20 MIN

## SKILL STATIONS #2

**1. A BUG'S LIFE**

Place pucks (food) in corner and net in opposite corner. Players (ants) control puck and try to put in net (ant hill) while coaches (grasshoppers) try to take pucks away. Player can try to take puck back from coach or go and get another puck. Ants try to get all the food into the ant hill before winter (the whistle).

**2. STATIONARY STICKHANDLING (2.1.14)**

Players find open space. Paint 2 dots on ice in front of each player approx. 1 metre apart. Players control the puck in a figure 8 motion around the dots. Elbows away from the body, roll the wrists.

**3. GARBAGE DUMP**

Divide group into 2 teams. Assign each team to one face-off circle as a home base. Scatter pucks around end zone. On signal the players must skate around and stop to pick up one object at a time (piece of garbage) and return it to their home base (dump). Players must leave their gloves on. Players must stop at each piece of garbage. Team that collects the most garbage wins.

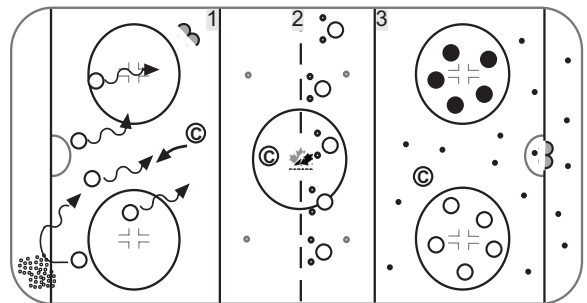

## 10 MIN

## FUN GAME

**CROSS ICE SCRIMMAGE**

No nets - use 1 pylon - must hit pylon to score - no goalies. Continuous play - if a goal is scored players give puck to coach who shoots it in to area and play continues. If stronger players monopolize the puck, add another puck (or two).

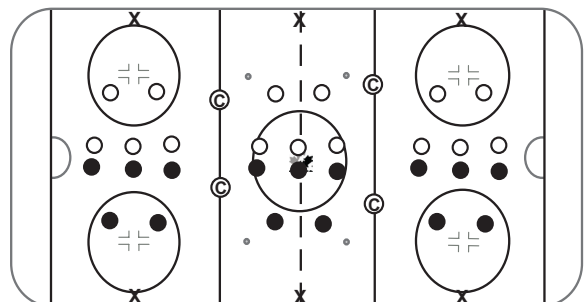

Do not forget to incorporate the Warm-up session prior to introducing your skill stations and the fun game at the end of your practice from the previous page.  
 Additional ice stations: You may choose either Option 1: Skill Stations #1 plus Skill Skations #2, Option 2: Skills Stations #2 repeated 3 times or Option 3: Skill Stations #3 only

**SKILL STATIONS #1 - 4 STATION SETUP**

- 1. FOREHAND AND BACKHAND SHOT (3.1.01/3.1.02)
- 2. STATIONARY STICKHANDLING (2.1.14)
- 3. STATIONARY STICKHANDLING (2.1.02/2.1.03/2.1.04)
- 4. SCATTER PUCK

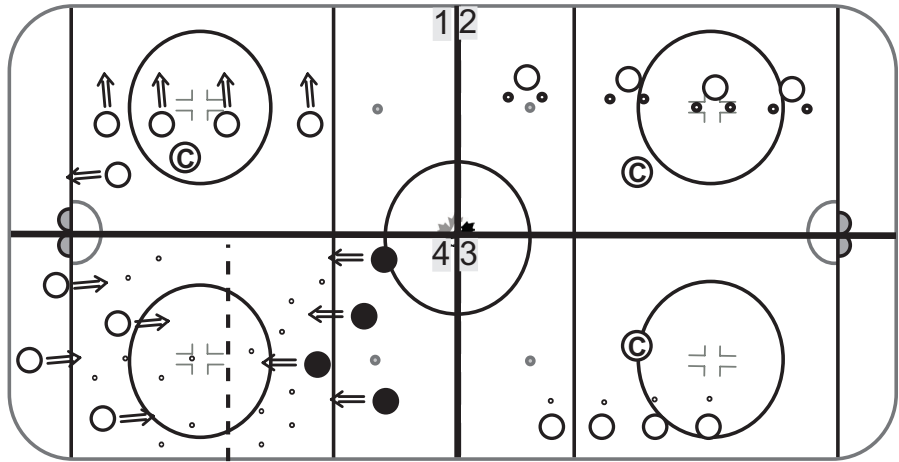

**SKILL STATIONS #2 - 2 STATION SETUP**

- 1. A BUG'S LIFE
- 2. GARBAGE DUMP

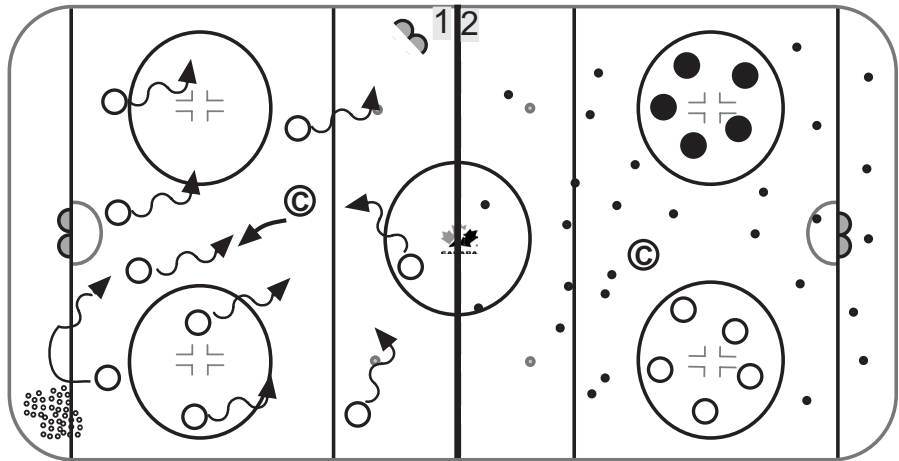

**SKILL STATIONS #3 - 6 STATION SETUP**

- 1. FOREHAND AND BACKHAND SHOT (3.1.01/3.1.02)
- 2. GARBAGE DUMP
- 3. STATIONARY STICKHANDLING (2.1.02/2.1.03/2.1.04)
- 4. STATIONARY STICKHANDLING (2.1.14)
- 5. SCATTER PUCK
- 6. A BUG'S LIFE

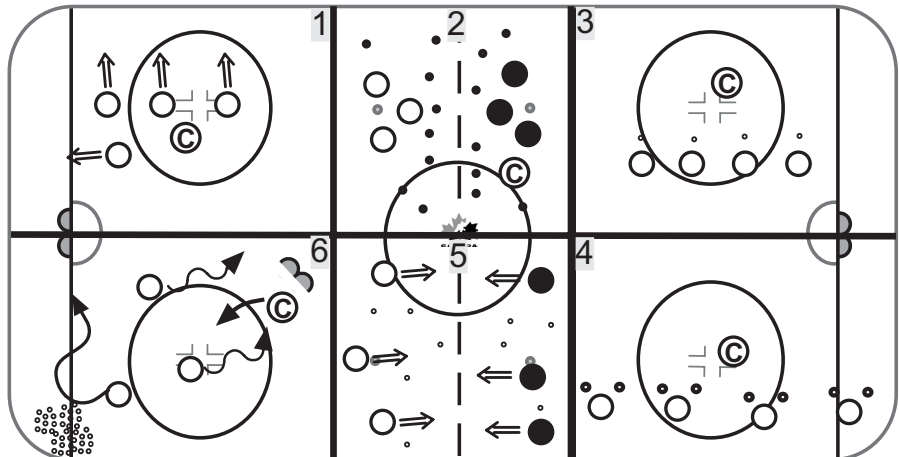

Session Objectives: 1. Introduce: Backward Stance, Walking Backwards, Gliding Backwards  
2. Review: ABC's, Forehand Shot, Backhand Shot, One O'clock - Eleven O'clock Stop

## 10 MIN

## WARM-UP

**CHAOS (2.2.01/2.2.02/2.2.03)**

Players skate around ice any direction handling puck. Put out nets for shooting, encourage players to bounce it off the boards, vary speed, change direction, stickhandle narrow, wide, and narrow-wide combination.

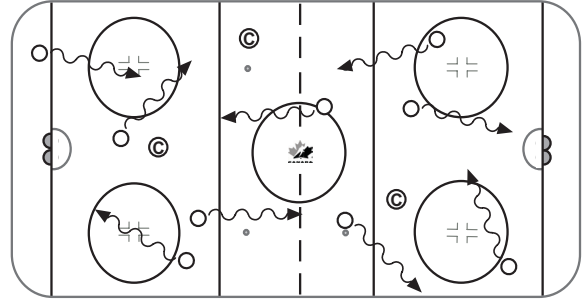

## 20 MIN

## SKILL STATIONS #1

**1. WALKING BACKWARDS**

Review and demonstrate key points of stance. Players go into stance and straighten up - 3-4 times. Players drop to knees and get back into stance. Players line-up on goal line facing end boards. Assume basic stance. Skates in inverted "V" - "pigeon-toed". Walk backwards toward blue line. Must lift skates and shift weight from side to side. Replace foot with toe turned in. Repeat 4-5 times.

**2. TOILET BOWL TAG**

Players play without sticks. Players must skate around end zone with hands on their knees. Coaches are "it" and must tag players. Tagged players must stand still with their arm straight out (flusher). To be freed, another player must skate under the flusher, stop and push arm down (flush the toilet).

**3. ONE O'CLOCK - ELEVEN O'CLOCK STOP (1.3.06)**

Players line up on boards. Each player in turn skates to 1st pylon and executes stop facing direction of next pylon. Next player goes when player in front stops at pylon. Review technique and correct.

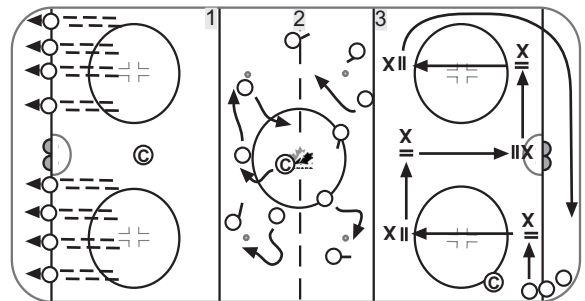

## 20 MIN

## SKILL STATIONS #2

**1. GLIDING BACKWARDS (1.5.03)**

Players push themselves away from boards and see how far they can glide backwards. Repeat several times (players can probably go at own pace - encourage them to repeat by trying to go farther each time). Review form - proper balance in the basic stance is the key - watch for players leaning forward and correct.

**2. FOREHAND AND BACKHAND SHOT (3.1.01/3.1.02)**

Divide group into 2 teams and assign them a "zone". Players must remain in "zone". Place small pylon in the middle of the ice. On signal, players shoot pucks at the pylon and try to move it toward the other team's "zone". Players can retrieve pucks but shots must come from inside their "zone". Team wins when it moves the pylon into the opponent's face-off circle. Repeat with Backhand shots only.

**3. HORSE AND BUGGY (1.5.03)**

Players partner off and face each other using 2 hockey sticks (hold blades forward facing down). Push partner backwards. Player being pushed assumes basic stance and glides on 2 skates backwards. Go slow and safe

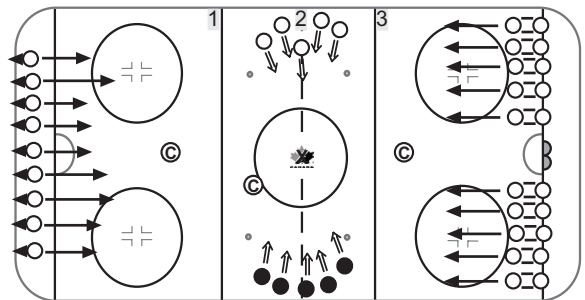

## 10 MIN

## FUN GAME

**BATTLESHIP**

Rink is a battleship, coach is the captain & players are the crew. Crew spreads out around ship and responds to captain's commands. Introduce 4 commands and play 5 minutes: "Torpedoes" - crew slides on stomach, "hands out, heads up"; "Submarine" - crew slides on back with leg in air (periscope); "Enemy Aircraft" - crew slides on knees and shoots down planes with sticks; "Storm" - crew skates and touches down one knee each stride (alternate knees); Introduce 5 more commands and play another 5 minutes: "Stern" - skate backwards to one end; "Bow" - skate forwards to other end; "Port" & "Starboard" - lateral crossovers to side; "Swab the Deck" - sweep snow with sticks; Man Overboard" crew dives into water and swims on stomachs

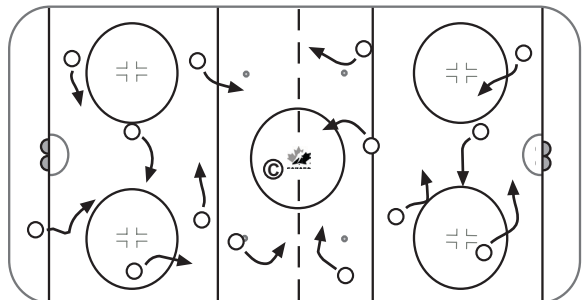

Do not forget to incorporate the Warm-up session prior to introducing your skill stations and the fun game at the end of your practice from the previous page.  
 Additional ice stations: You may choose either Option 1: Skill Stations #1 plus Skill Skatons #2, Option 2: Skills Stations #2 repeated 3 times or Option 3: Skill Stations #3 only

**SKILL STATIONS #1 - 4 STATION SETUP**

1. WALKING BACKWARDS
2. GLIDING BACKWARDS (1.5.03)
3. HORSE AND BUGGY (1.5.03)
4. TOILET BOWL TAG

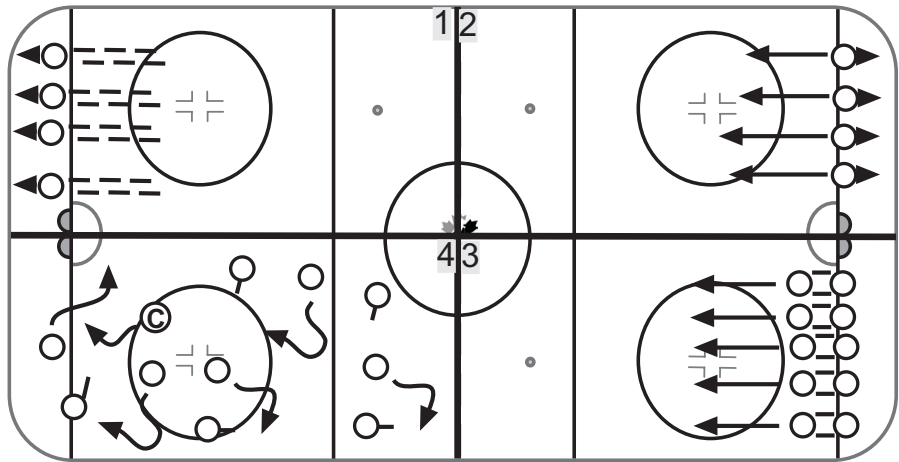

**SKILL STATIONS #2 - 2 STATION SETUP**

1. ONE O'CLOCK - ELEVEN O'CLOCK STOP (1.3.06)
2. FOREHAND AND BACKHAND SHOT (3.1.01/3.1.02)

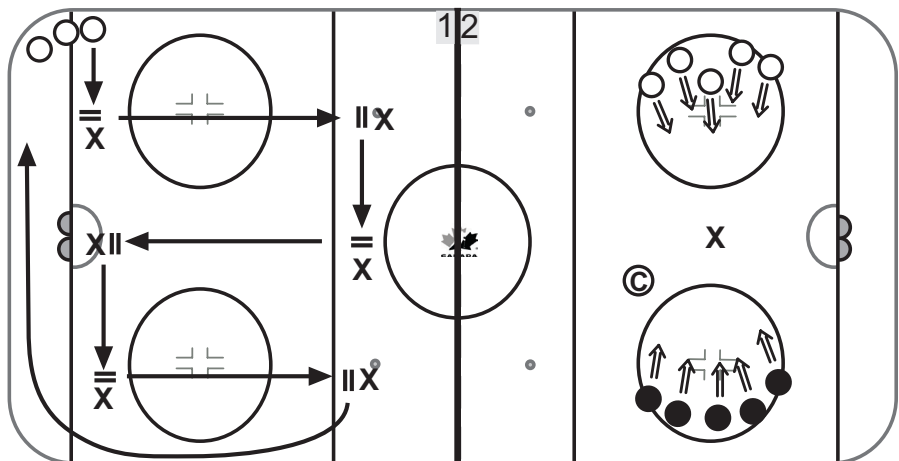

**SKILL STATIONS #3 - 6 STATION SETUP**

1. WALKING BACKWARDS
2. TOILET BOWL TAG
3. FOREHAND AND BACKHAND SHOT (3.1.01/3.1.02)
4. ONE O'CLOCK - ELEVEN O'CLOCK STOP (1.3.06)
5. GLIDING BACKWARDS (1.5.03)
6. HORSE AND BUGGY (1.5.03)

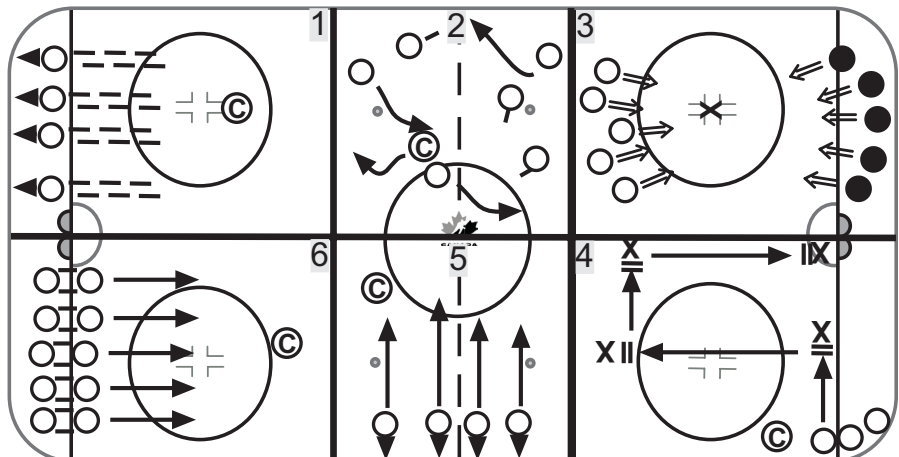



Session Objectives: 1. Introduce: C-Cut, Backward Striding, Stick Checks  
2. Review: ABC's, Starting & Skating with the Puck

## 10 MIN

## WARM-UP

**WARM UP (1.1.04/1.3.06)**

Skate clockwise direction; between blue lines skate backwards, jump the lines on one foot, exaggerated stride, stop 'n go on red line (always facing same side of rink), speed up. Add pucks if desired.

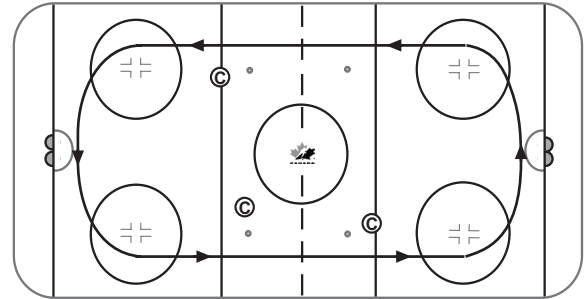

## 20 MIN

## SKILL STATIONS #1

**1. C-CUTS BACKWARDS (1.5.01)**

Review and demonstrate key points of C-Cut. Have players place their hands on the boards shoulder width apart for balance. Practice making C-Cuts with left skate then right skate.

**2. STATIONARY STICKHANDLING (2.1.05)**

Line players up in stickhandling position with a puck in front of them. Have players stickhandle the puck on the forehand side, then to the front and finally to the backhand side.

**3. BUGS LIFE**

Place pucks (food) in corner and net in opposite corner. Players (ants) control puck and try to put in net (ant hill) while coaches (grasshoppers) try to take pucks away. Player can try to take puck back from coach or go and get another puck. Ants try to get all the food into the ant hill before winter (the whistle)

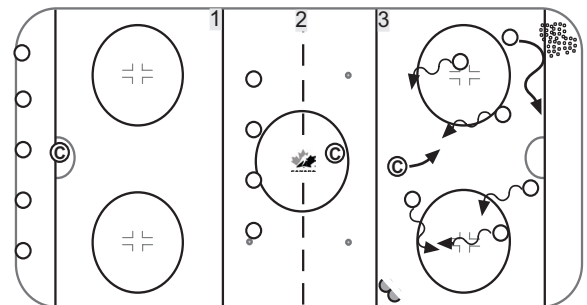

## 20 MIN

## SKILL STATIONS #2

**1. BACKWARD STRIDING (1.5.01/1.5.02)**

Players line up on goal line facing end boards. On signal players perform C-Cut with one foot to blue line. Return using other foot. Same formation, have players put skates in inverted "V" - "pigeon-toed". Walk backwards toward blue line. Remind players to lift skates and feel the weight shift from side to side. Explain to players to put it all together and demonstrate. Players start on goal line, start with C-Cuts with alternate feet then push and glide backwards to blue line. Return. Check for good backward stance, stick in one hand, glide foot directly under centre of gravity, push foot extends sideways using front part of blade.

**2. STICK CHECKS (4.2.01/4.2.02)**

Review and demonstrate stick checks. Play ringette. Have players turn their sticks upside down and use butt-end of stick in the ring. Players will have better success carrying the ring. Use stick checks to take ring from opponent.

**3. C-CUTS BACKWARDS (1.6.13)**

Players line-up around face-off circle. Assume backward stance. Turn toe of one foot in. Shift weight to that foot. Push away using a C-Cut. Return skate to original position. Repeat around circle using one leg only. Give players individual attention.

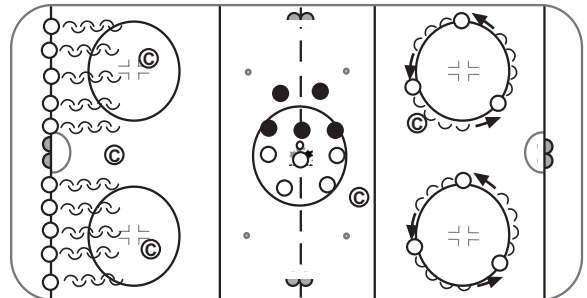

## 10 MIN

## FUN GAME

**TRAIN RELAY**

Each player is a car in a train, coupled to car in front by holding player in front by waist. On signal the whole team pushes to the far goal line skating forwards. Team cannot lose hold of player in front, nor crash into boards. Repeat as time permits. Change engine & caboose. Requires team work and co-operation. Novice I's may want to break up into 2 trains.

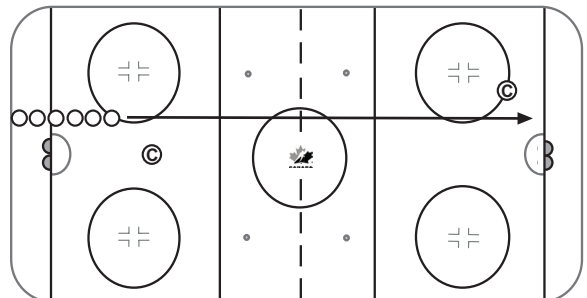

Do not forget to incorporate the Warm-up session prior to introducing your skill stations and the fun game at the end of your practice from the previous page.  
 Additional ice stations: You may choose either Option 1: Skill Stations #1 plus Skill Skatons #2, Option 2: Skills Stations #2 repeated 3 times or Option 3: Skill Stations #3 only

**SKILL STATIONS #1 - 4 STATION SETUP**

- 1. C-CUTS BACKWARDS (1.5.01)
- 2. STATIONARY STICKHANDLING (2.1.05)
- 3. STICK CHECKS (4.2.01/4.2.02)
- 4. C-CUTS BACKWARDS (1.6.13)

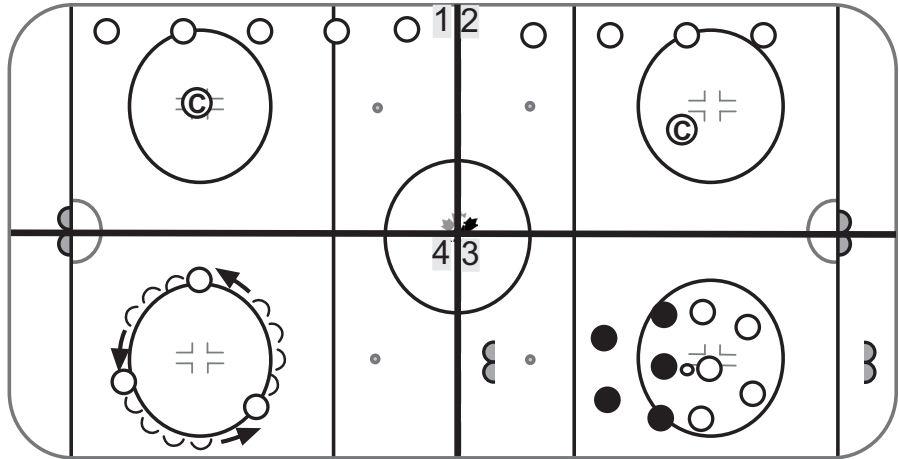

**SKILL STATIONS #2 - 2 STATION SETUP**

- 1. BACKWARD STRIDING (1.5.01/1.5.02)
- 2. BUGS LIFE

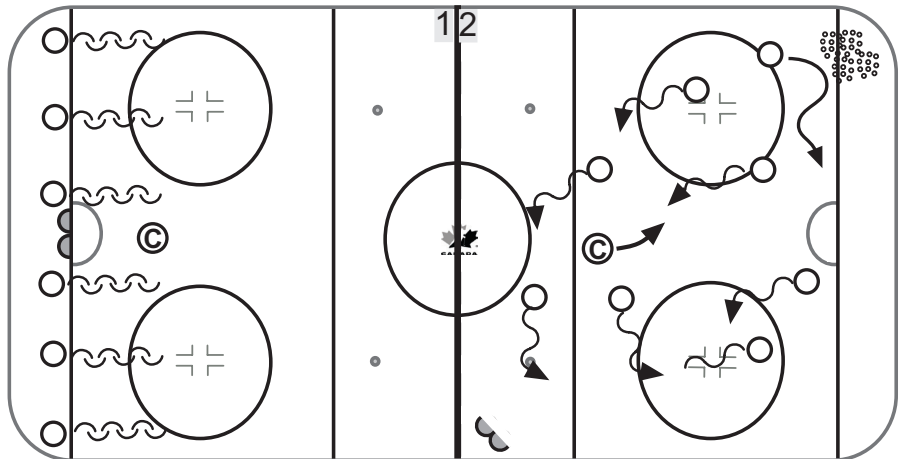

**SKILL STATIONS #3 - 6 STATION SETUP**

- 1. C-CUTS BACKWARDS (1.5.01)
- 2. STATIONARY STICKHANDLING (2.1.05)
- 3. C-CUTS BACKWARDS (1.6.13)
- 4. STICK CHECKS (4.2.01/4.2.02)
- 5. BACKWARD STRIDING (1.5.01/1.5.02)
- 6. BUGS LIFE

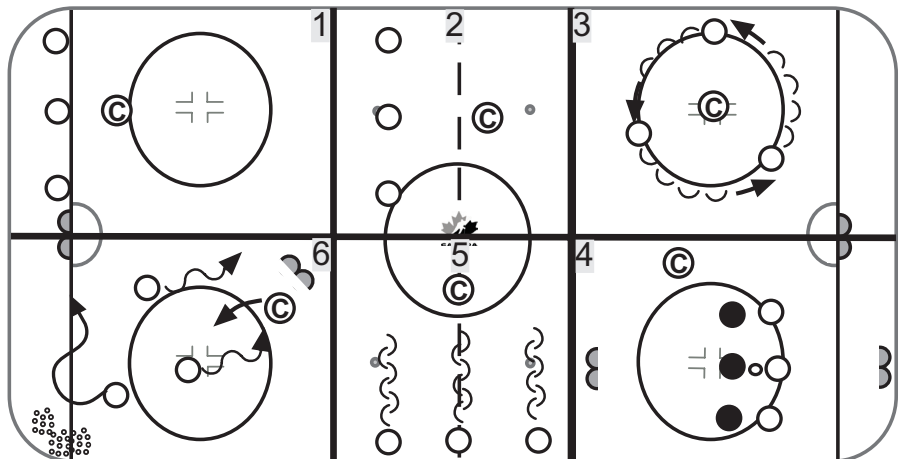



Session Objectives: 1. Introduce: : Two-Leg Backward Stop, Weaving with the Puck, Edge Control  
2. Review: ABC's, C-Cut, Backward Striding, Stick Checks, Stationary Stickhandling

## 10 MIN

## WARM-UP

**WARM UP (1.1.04/1.4.12/1.3.06)**

Skate clockwise direction; between blue lines skate backwards, jump the lines on one foot, exaggerated stride, stop 'n go on red line (always facing same side of rink), speed up. Add pucks if desired.

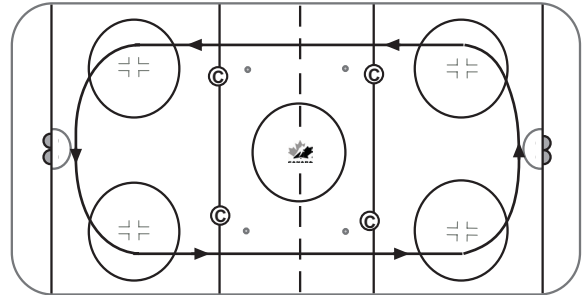

## 20 MIN

## SKILL STATIONS #1

**1. BACKWARDS STRIDING (1.5.01/1.5.02)**

Review and demonstrate key points of C-Cut. Players line up on goal line facing end boards. On signal players perform C-Cut with one foot to blue line. Return using other foot. Same formation, have players put skates in inverted "V" - "pigeon-toed". Walk backwards toward blue line. Remind players to lift skates and feel the weight shift from side to side. Explain to players to put it all together and demonstrate. Players start on goal line, start with C-Cuts with alternate feet then push and glide backwards to blue line. Return. Check for good backward stance, stick in one hand, glide foot directly under centre of gravity, push foot extends sideways using front part of blade.

**2. TWO-LEG BACKWARD STOP (1.3.11)**

Review and demonstrate key points. Players line-up facing boards in basic stance. On signal, they push themselves away from the boards and glide backwards. Initiate stop by turning toes outward and leaning body slightly forward. Repeat 4-5 times. Red Light, Green Light - On "green light" start skating backward across ice using C-cut. On "yellow light" glide backwards. On "red light" stop using backward two leg backward stop.

**3. WEAVING WITH THE PUCK (2.2.08)**

Each player with a puck. Move left to right in front of body. Move puck on side from front to back. Players skate forward at an easy pace while stickhandling. Player weaves with puck through the first 4 pylons, perform a 360° turn around pylon 5, stickhandles between pylons 5 & 6 and perform a glide turn around the final pylon returning to original position.

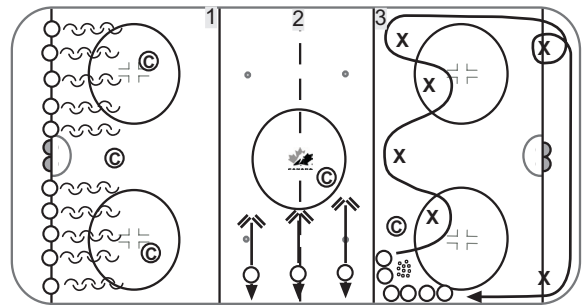

## 20 MIN

## SKILL STATIONS #2

**1. STICK CHECKS (4.2.01/4.2.02)**

Review stick checks. Play ringette. Have players turn their sticks upside down and use butt-end of stick in the ring. Players will have better success carrying the ring. Use stick checks to take ring from opponent.

**2. STATIONARY STICKHANDLING (2.1.05)**

Line players up in stickhandling position with a puck in front of them. Have players stickhandle the puck on the forehand side, then to the front and finally to the backhand side.

**3. FIGURE 8'S BACKWARDS - INSIDE EDGE (1.2.03)**

Review and demonstrate key points. Players ride inside edge in a figure 8 pattern. Start on left skate and ride inside edge until the player has completed a full circle, then switch to right skate to complete figure 8 formation. Emphasize proper knee bend and upper body control.

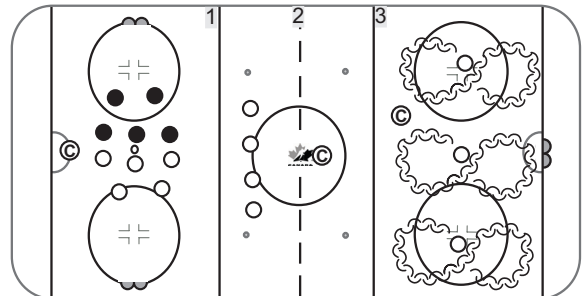

## 10 MIN

## FUN GAME

**STEAL THE TREASURE**

Box, crate or bucket (treasure chest) placed at one end. All pucks (treasure) at players' end. Players must pick up a puck skate to other end and place in crate (steal the pirate's treasure). Coaches (pirates) try to tag players. If tagged players must drop puck and go get another. Players must leave gloves on for safety.

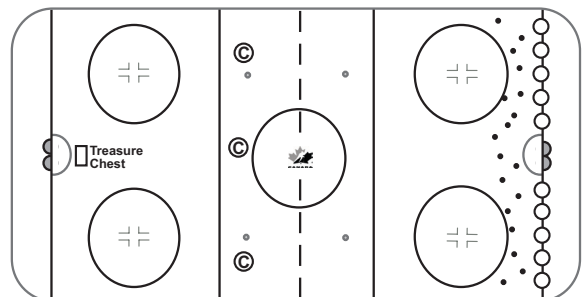

Do not forget to incorporate the Warm-up session prior to introducing your skill stations and the fun game at the end of your practice from the previous page.  
 Additional ice stations: You may choose either Option 1: Skill Stations #1 plus Skill Skations #2, Option 2: Skills Stations #2 repeated 3 times or Option 3: Skill Stations #3 only

**SKILL STATIONS #1 - 4 STATION SETUP**

- 1. BACKWARDS STRIDING (1.5.01/1.5.02)
- 2. TWO-LEG BACKWARD STOP (1.3.11)
- 3. FIGURE 8'S BACKWARDS - INSIDE EDGE (1.2.03)
- 4. STATIONARY STICKHANDLING (2.1.05)

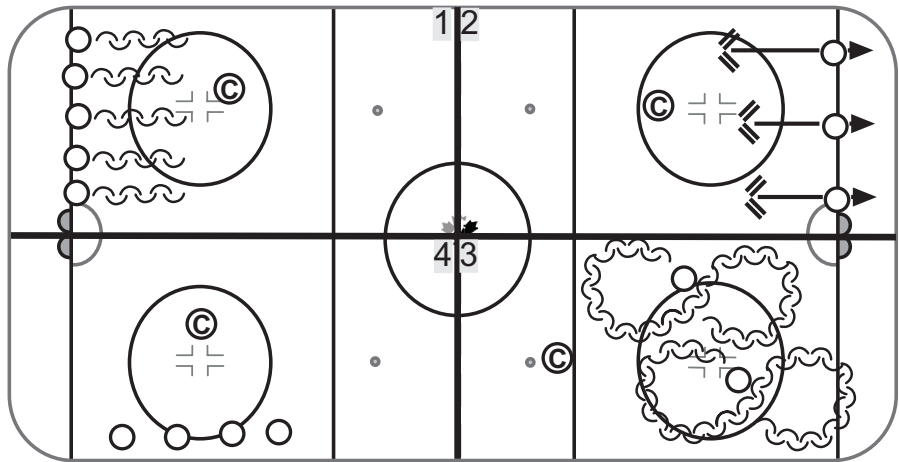

**SKILL STATIONS #2 - 2 STATION SETUP**

- 1. STICK CHECKS (4.2.01/4.2.02)
- 2. WEAVING WITH THE PUCK (2.2.08)

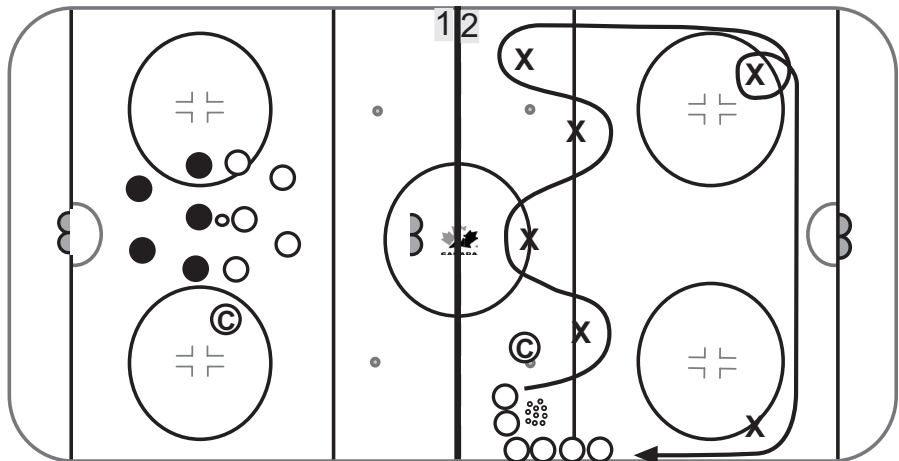

**SKILL STATIONS #3 - 6 STATION SETUP**

- 1. BACKWARDS STRIDING (1.5.01/1.5.02)
- 2. TWO-LEG BACKWARD STOP (1.3.11)
- 3. FIGURE 8'S BACKWARDS - INSIDE EDGE (1.2.03)
- 4. WEAVING WITH THE PUCK (2.2.08)
- 5. STATIONARY STICKHANDLING (2.1.05)
- 6. STICK CHECKS (4.2.01/4.2.02)

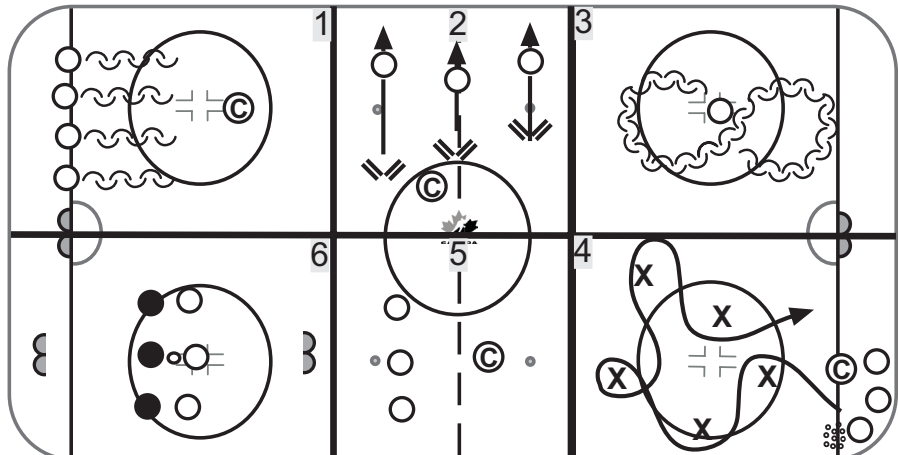

Session Objectives: 1. Introduce: Skating & Shooting, Tight Turns  
2. Review: C-Cut, Backward Striding, Two-Leg Backward Stop, Weaving with the Puck, Stationary Stickhandling

## 10 MIN

## WARM-UP

## WARM UP (1.5.02/1.1.09//1.4.12/1.5.04)

Skate clockwise direction, between blue lines: backwards c-cuts alternating, gliding with knee bend, exaggerated stride, gliding on one skate backwards, speed up.

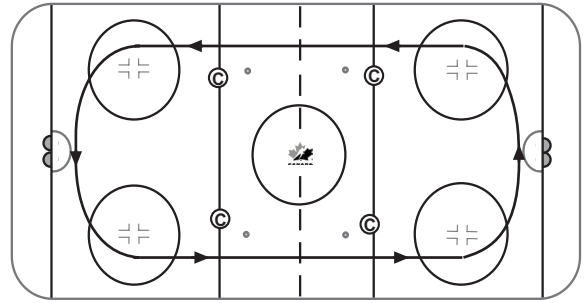

## 20 MIN

## SKILL STATIONS #1

## 1. SKATING AND SHOOTING

Divide group in 2 corners. Extra pucks in corners. Set pylons at top of each circle. Players carry puck out of corner, around pylons and shoot from slot. Send players in quick succession.

## 2. TWO LEG BACKWARD STOP (1.3.11)

Review backward striding. Have players try walking backward "pigeon-toed" to promote shifting weight from one foot to the other. Players find a partner. Place pylon approx. 20m across ice for each pair. 1st player performs C-cut to start then strides backwards to pylon and performs two leg backward stop. Player returns to partner who then performs same sequence. Coach reviews form and provides feedback.

## 3. TIGHT TURNS (1.6.02)

Review and demonstrate key points. Set up zig-zag course of pylons. Players execute a tight turn around each pylon in the formation. Send player when player in front reaches 2nd pylon. Coaches provide feedback.

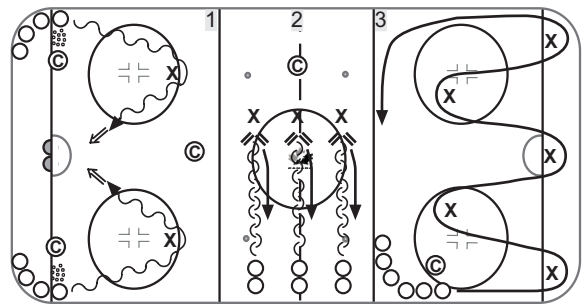

## 20 MIN

## SKILL STATIONS #2

## 1. BACKWARDS TAG

Coach is "it". All players (& coaches) skate backwards at all times. Once tagged a player helps "it". Players carry stick while they are "free", discard stick once they are tagged (so others can tell they are "it"). Last player left wins.

## 2. STATIONARY STICKHANDLING (2.1.02/2.1.03/2.1.04/2.1.05/2.1.06)

Line players up in stickhandling position with a puck in front of them. Have players practice narrow, wide, narrow-wide combination, and side-front-side stickhandling patterns while standing on right foot only. Repeat with left foot.

## 3. WEAVING WITH PUCK (2.2.08)

Player weaves with puck through the first 4 pylons, performs 360° turn around pylon 5, stickhandles between pylons 5 & 6 and does glide turn around the final pylon returning to original position.

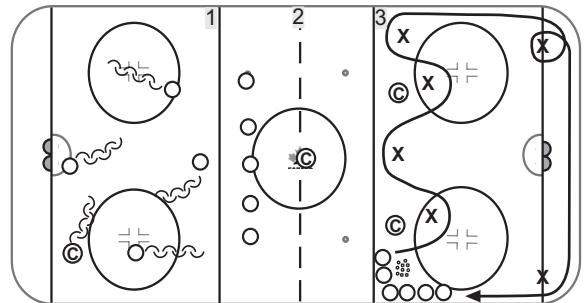

## 10 MIN

## FUN GAME

## SOCCER

Play soccer in cross ice format. No sticks.

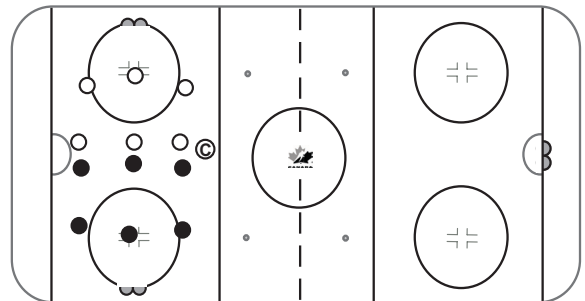

Do not forget to incorporate the Warm-up session prior to introducing your skill stations and the fun game at the end of your practice from the previous page.  
 Additional ice stations: You may choose either Option 1: Skill Stations #1 plus Skill Skations #2, Option 2: Skills Stations #2 repeated 3 times or Option 3: Skill Stations #3 only

**SKILL STATIONS #1 - 4 STATION SETUP**

1. TIGHT TURNS 1.6.02
2. TWO LEG BACKWARD STOP (1.3.11)
3. STATIONARY STICKHANDLING (2.1.02/2.1.03/2.1.04/2.1.05/2.1.06)
4. SKATING AND SHOOTING

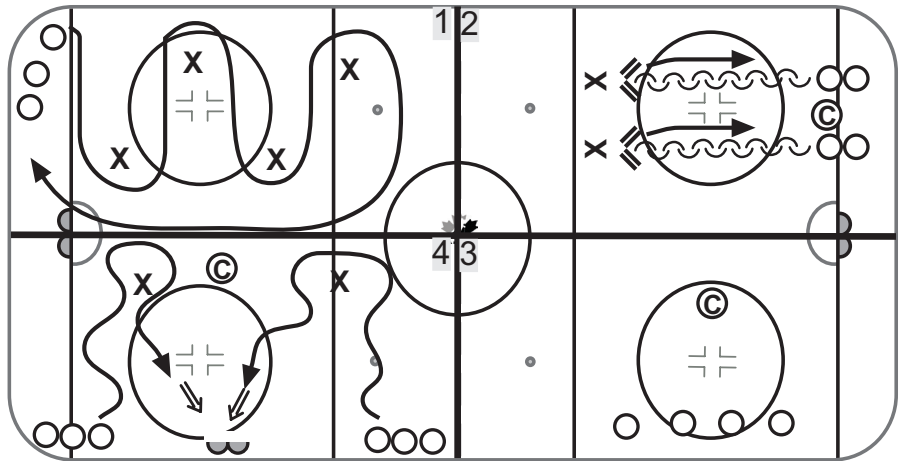

**SKILL STATIONS #2 - 2 STATION SETUP**

1. BACKWARDS TAG
2. WEAVING WITH PUCK (2.2.08)

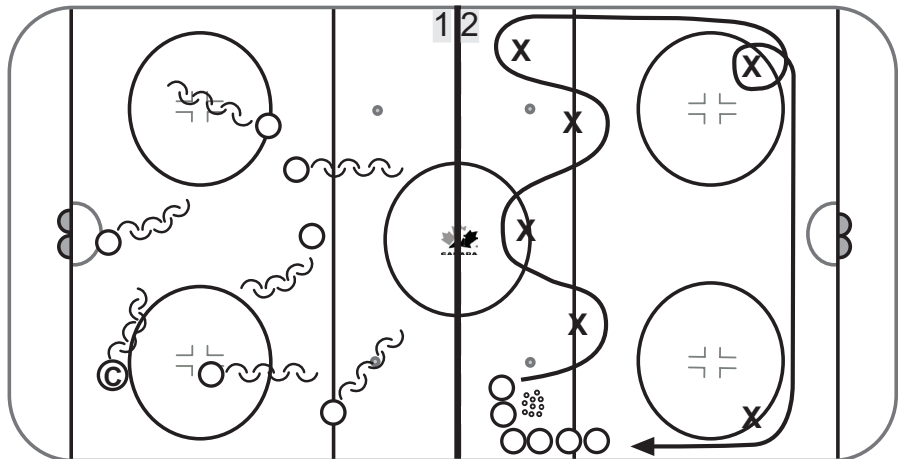

**SKILL STATIONS #3 - 6 STATION SETUP**

1. SKATING AND SHOOTING
2. TIGHT TURNS (1.6.02)
3. TWO LEG BACKWARD STOP (1.3.11)
4. WEAVING WITH PUCK (2.2.08)
5. SKATING AND SHOOTING
6. BACKWARDS TAG

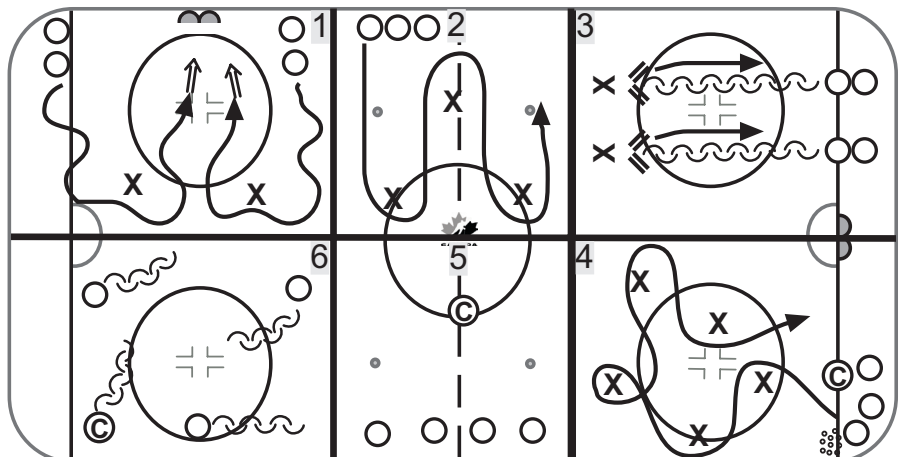

Session Objectives: 1. Review: ABC's, Skating & Shooting, Tight Turns, Backward Striding, Two-Leg Backward Stop, Weaving with the Puck, Stationary Stickhandling

## 10 MIN

## WARM-UP

## WARM UP

Skate clockwise direction, between blue lines skate backwards c-cuts alternating, glide with knee bend, exaggerated stride, glide on one skate backwards, speed up.

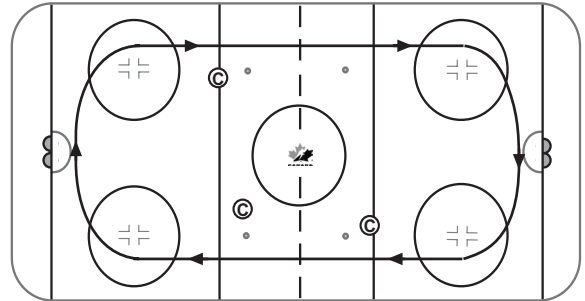

## 20 MIN

## SKILL STATIONS #1

## 1. SKATING AND SHOOTING

Divide group in 2 corners. Extra pucks in corners. Set pylons at top of each circle. Players carry puck out of corner, around pylons and shoots from slot. Send players in quick succession.

## 2. BACKWARDS TAG

All players (& coaches) skate backwards at all times. Once tagged a player helps "it". Players carry stick while they are "free", discard stick once they are tagged (so others can tell they are "it"). Last player left wins.

## 3. SHOOTING AND SCORING

On each side of the ice set up long stick across 2 pylons at approx. hash marks and pylon just short of blue line. Leave ½ of pucks near top of circles. Player must skate toward blue line, slide on stomach under stick ("hands out - head up"), regain feet, do tight turn around pylon, skate toward the net, pick up puck and score. Return to line.

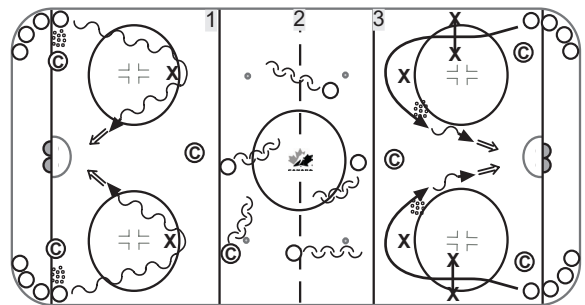

## 20 MIN

## SKILL STATIONS #2

## 1. TIGHT TURNS 1.6.02

Review and demonstrate key points. Set up zig-zag course of pylons. Players execute a tight turn around each pylon in the formation. Send player when player in front reaches 2nd pylon. Coaches provide feedback.

## 2. STATIONARY STICKHANDLING (2.1.08/2.1.09)

Line players up in stickhandling position with a puck in front of them. Have players stickhandling with hands together then hands wide.

## 3. WEAVING WITH PUCK (2.2.08)

Player weaves with puck through the first 4 pylons, performs 360° turn around pylon 5, stickhandles between pylons 5 & 6 and does glide turn around the final pylon returning to original position.

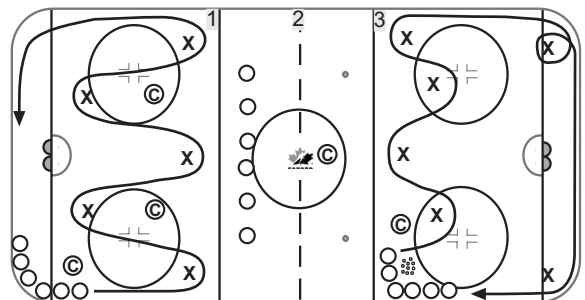

## 10 MIN

## FUN GAME

## CROSS ICE SCRIMMAGE

No nets - use 1 pylon - must hit pylon to score - no goalies. Continuous play - if a goal is scored players give puck to coach who shoots it in to area and play continues. If stronger players monopolize the puck, add another puck (or two).

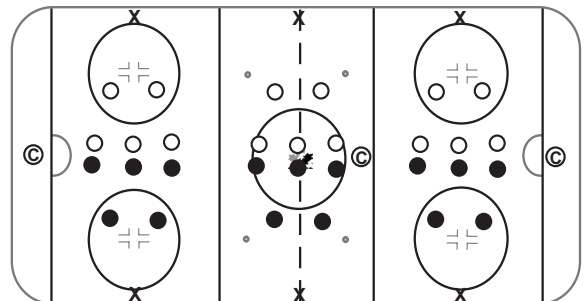

Do not forget to incorporate the Warm-up session prior to introducing your skill stations and the fun game at the end of your practice from the previous page.  
 Additional ice stations: You may choose either Option 1: Skill Stations #1 plus Skill Skatons #2, Option 2: Skills Stations #2 repeated 3 times or Option 3: Skill Stations #3 only

**SKILL STATIONS #1 - 4 STATION SETUP**

- 1. TIGHT TURNS (1.6.02)
- 2. STATIONARY STICKHANDLING (2.1.08/2.1.09)
- 3. SKATING AND SHOOTING
- 4. BACKWARDS TAG

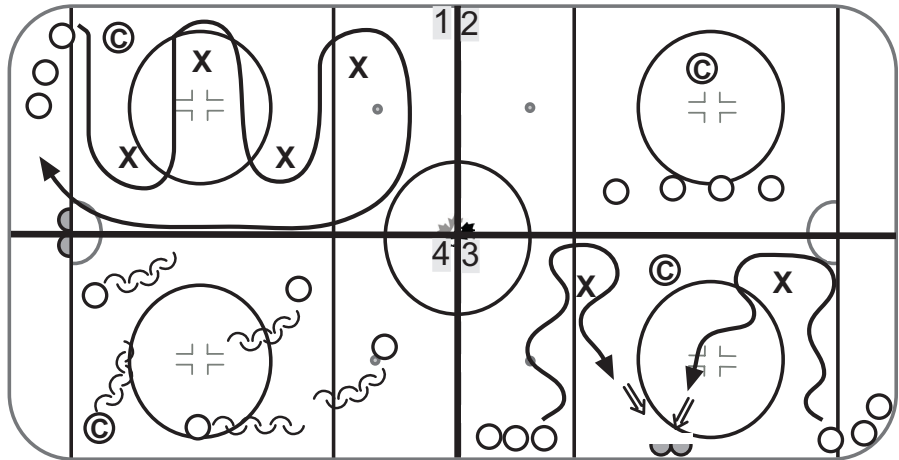

**SKILL STATIONS #2 - 2 STATION SETUP**

- 1. WEAVING WITH PUCK (2.2.08)
- 2. SHOOTING AND SCORING

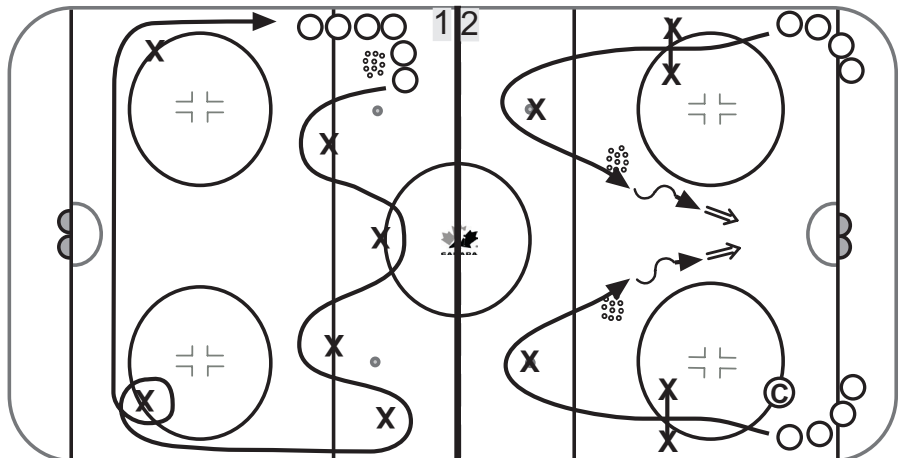

**SKILL STATIONS #3 - 6 STATION SETUP**

- 1. SKATING AND SHOOTING
- 2. TIGHT TURNS (1.6.02)
- 3. BACKWARDS TAG
- 4. WEAVING WITH PUCK (2.2.08)
- 5. STATIONARY STICKHANDLING (2.1.08/2.1.09)
- 6. BACKWARDS TAG

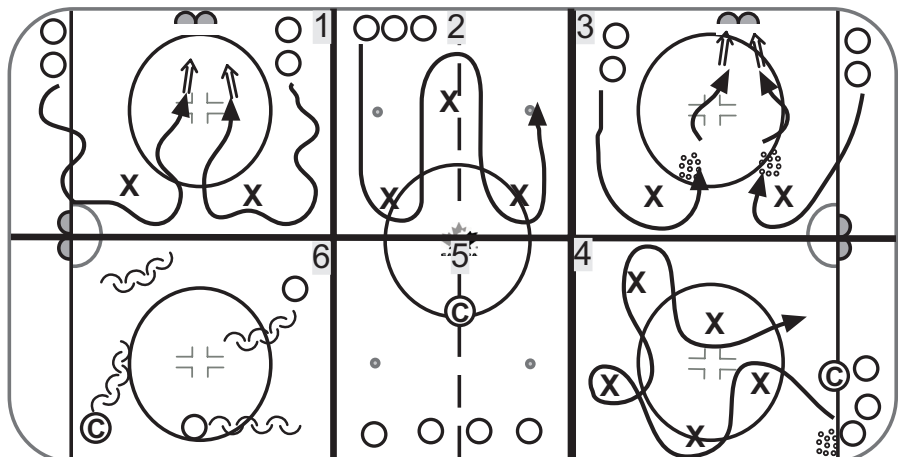



Session Objectives: 1. Introduce: 1 Foot Stop, V Start, 360's  
2. Review: ABC's, C-Cut, Backward Striding, Two-Leg Backward Stop, Tight Turns

## 10 MIN

## WARM-UP

**CHAOS (2.2.01/2.2.02/2.2.03/2.2.04/2.2.09)**

Players skate around ice any direction handling puck. Put out nets for shooting, encourage players to stickhandle narrow, wide, narrow-wide combination, side-front-side, and on one leg.

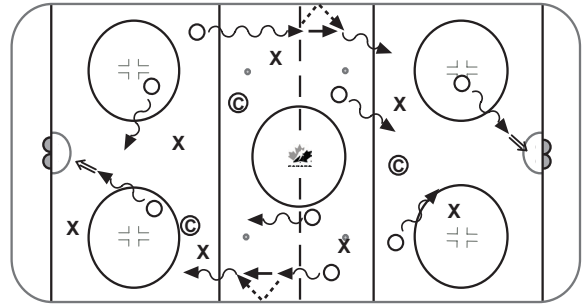

## 20 MIN

## SKILL STATIONS #1

**1. FOLLOW THE LEADER (1.1.04/1.1.09/1.1.05/1.1.12/1.5.04/1.6.04/1.6.12)**

Challenge the players to do the following things (requires enthusiasm - act surprised when kids accomplish tasks, tell them they can't do the next one): jumping on one foot, gliding with knee bend, gliding - arm pump, lateral crossovers, gliding on one skate backwards, 360's, crossovers - three quick - left and right.

**2. V-START AND TIGHT TURNS (1.3.02/1.6.02)**

Review key points of front start and demonstrate while stationary for organization. Players in basic stance. On signal they practice opening skates into a "V" position by toeing outwards. Try to open as far as possible. Players partner off. Place pylons ½ way across ice - 1 pylon for every pair of players. On signal 1st player in each line opens skates into "V" position and takes 4-5 running strides and continues to pylon, executes a tight turn around pylon and returns to partner who then goes. Review form and correct flaws. Continuous drill. Halfway through change direction of turn.

**3. COPS AND ROBBERS**

Coaches act as cops, players as robbers. Players scatter in zone without sticks. When player is tagged goes to jail (net). Players in jail can be set free by being tagged by a free player.

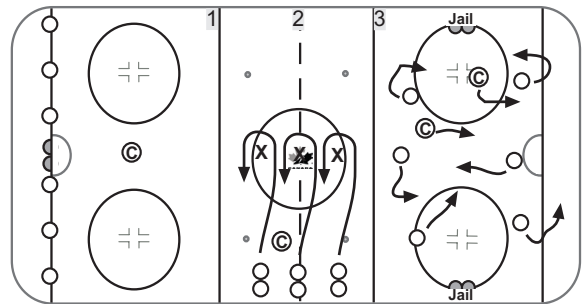

## 20 MIN

## SKILL STATIONS #2

**1. ONE FOOT STOP (1.3.07)**

Review and demonstrate. Set out pylons halfway between goal line and blue line. Divide players into groups corresponding to pylons. Players start using front start then glide toward pylon on 2 skates. Execute one foot stop and spray snow on the pylon. Player continues to blue line and next player goes. When group finishes, repeat returning to goal line and stop facing same side (spray other side of pylon). Coaches should review form.

**2. TWO LEG BACKWARD STOP (1.3.11)**

Review key points of basic stance, C-Cut, striding and two leg backward stop. Players pair up on side boards facing boards. On signal 1st player performs C-Cut to start, alternate feet, then push and glide to a line halfway across ice. Use two leg backward stop. Execute front V Start and return to partner. Check for good backward stance, stick in one hand, glide foot directly under centre of gravity, push foot extends sideways using front part of blade. For players that do not shift weight properly have players put skates in inverted "V" - "pigeon-toed". Walk backwards. Remind players to lift skates and feel the weight shift from side to side. Relay race - same format.

**3. 360'S (1.6.04)**

Review and demonstrate. Players line up on boards. On signal players skate to first hash mark and execute a 360, then continue to far hash mark and execute a second 360 in the opposite direction. Repeat with a puck.

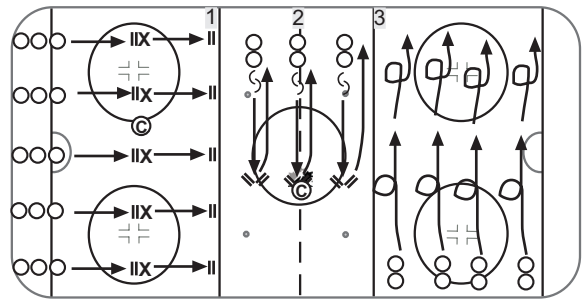

## 10 MIN

## FUN GAME

**A BUGS LIFE**

Place pucks (food) at centre ice and nets at each end. Players (ants) control puck and try to put in nets (ant hills) while coaches (grasshoppers) try to take pucks away. Player can try to take puck back from coach or go and get another puck. Ants try to get all the food into the ant hill before winter (the whistle).

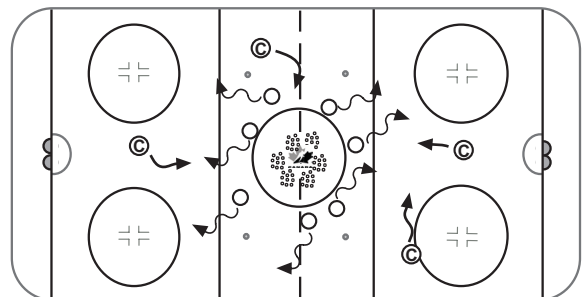



Do not forget to incorporate the Warm-up session prior to introducing your skill stations and the fun game at the end of your practice from the previous page.  
 Additional ice stations: You may choose either Option 1: Skill Stations #1 plus Skill Skations #2, Option 2: Skills Stations #2 repeated 3 times or Option 3: Skill Stations #3 only

**SKILL STATIONS #1 - 4 STATION SETUP**

1. TWO LEG BACKWARD STOP (1.3.11)
2. V-START AND TIGHT TURNS (1.3.02/1.6.02)
3. 360'S (1.6.04)
4. FOLLOW THE LEADER (1.1.04/1.1.09/1.1.05/1.1.12/1.5.04/1.6.04/1.6.12)

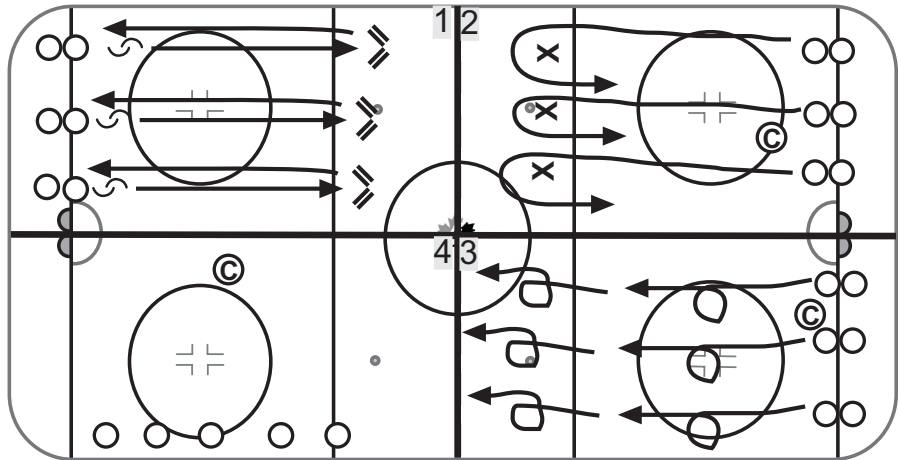

**SKILL STATIONS #2 - 2 STATION SETUP**

1. ONE FOOT STOP (1.3.07)
2. COPS AND ROBBERS

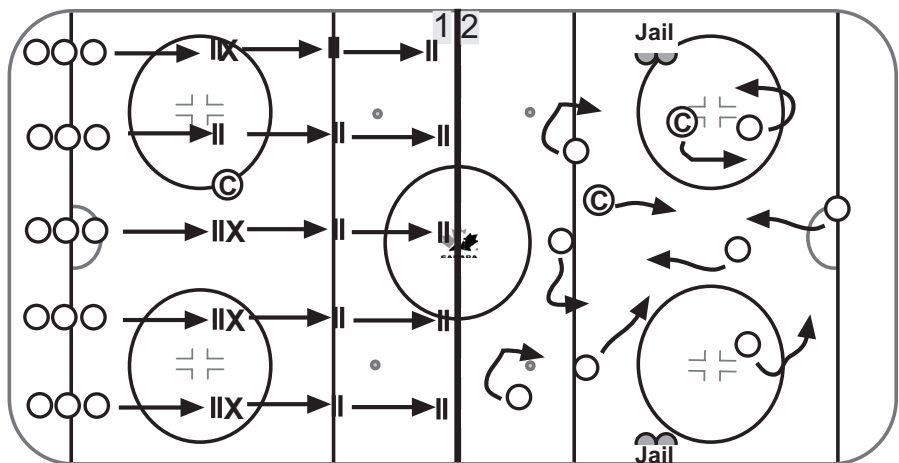

**SKILL STATIONS #3 - 6 STATION SETUP**

1. ONE FOOT STOP (1.3.07)
2. FOLLOW THE LEADER (1.1.04/1.1.09/1.1.05/1.1.12/1.5.04/1.6.04/1.6.12)
3. 360'S (1.6.04)
4. V-START AND TIGHT TURNS (1.3.02/1.6.02)
5. TWO LEG BACKWARD STOP (1.3.11)
6. COPS AND ROBBERS

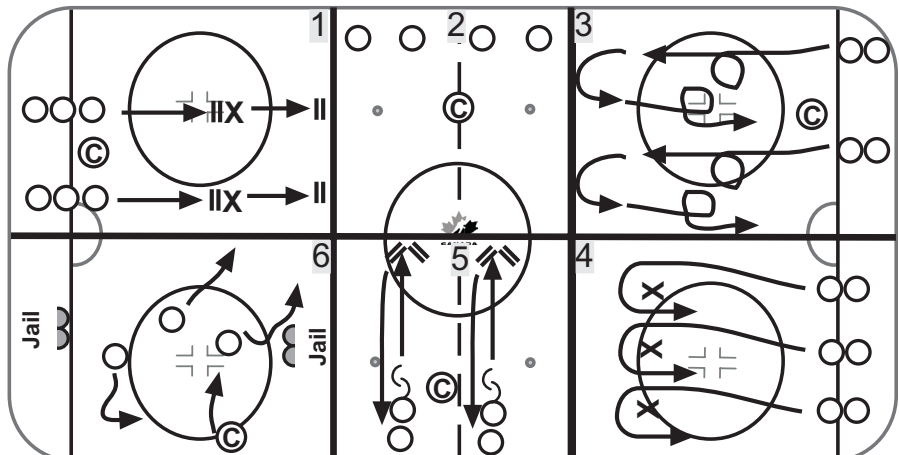



U7  EVALUATION ITEM  1=weak, 10=strong	Player																													
	Name 1		Name 2		Name 3		Name 4		Name 5		Name 6		Name 7		Name 8		Name 9		Name 10		Name 11		Name 12		Name 13		Name 14		Name 15	
	1	R	2	R	3	R	4	R	5	R	6	R	7	R	8	R	9	R	10	R	11	R	12	R	13	R	14	R	15	R
<b>Balance and Agility</b>																														
1. Gliding with knee bend																														
2. Gliding on one skate - backward																														
3. Lateral crossovers - continuous																														
<b>Edge Control</b>																														
4. Figure 8's - backward - inside edge																														
<b>Forward Skating and Striding</b>																														
5. Exaggerated stride																														
6. C-cuts - alternating																														
7. Gliding on two skates - backward																														
<b>Starting and Stopping</b>																														
8. Outside leg stop																														
9. Backward c-cut start																														
10. Front v-start																														
11. Two-leg backward stop																														
<b>Turning and Crossovers</b>																														
12. Tight turns																														
13. 360's - left and right																														
14. C-cuts - around circle - outside foot - backward																														
<b>Stationary Puck Control</b>																														
15. Side - front - side																														
16. Hands wide																														
17. Hands together																														
18. Narrow and wide combination																														
<b>Moving Puck Control</b>																														
19. One leg - left and right																														
20. Narrow and wide combination																														
21. Weaving with puck																														
<b>Sweep Shot</b>																														
22. Sweep shot - forehand																														
23. Sweep shot - backhand																														
<b>AVERAGE SCORE</b>																														
<b>OVERALL RANK</b>																														



Team name: \_\_\_\_\_

Date of Evaluation: \_\_\_\_\_

Age division: \_\_\_\_\_

Coach: \_\_\_\_\_

Note: Evaluate players against players on own team

For an electronic version of this checklist, please visit [www.hockeycanada.ca](http://www.hockeycanada.ca)



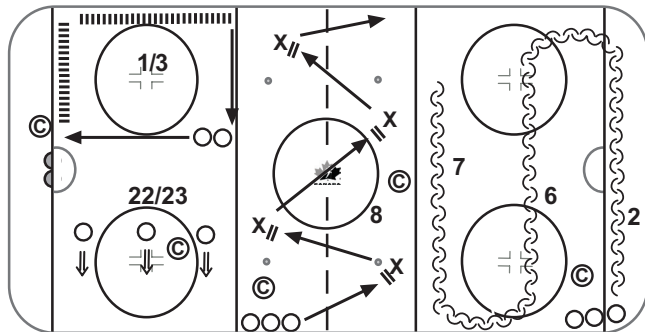

1. Gliding with knee bend
2. Gliding on one skate - backward
6. C-cuts - alternating
7. Gliding on two skates - backward
8. Outside leg stop
22. Sweep shot - forehand
23. Sweep shot - backhand

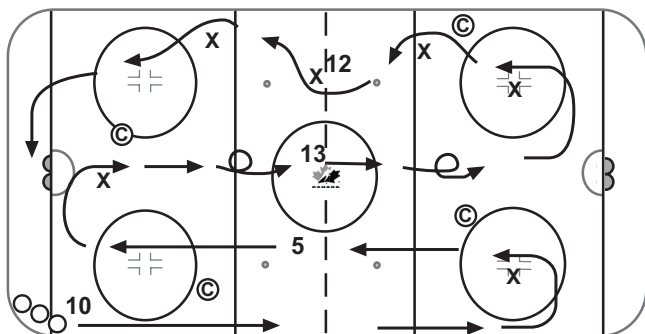

10. Front v-start
5. Exaggerated stride
12. Tight turns
13. 360's - left and right

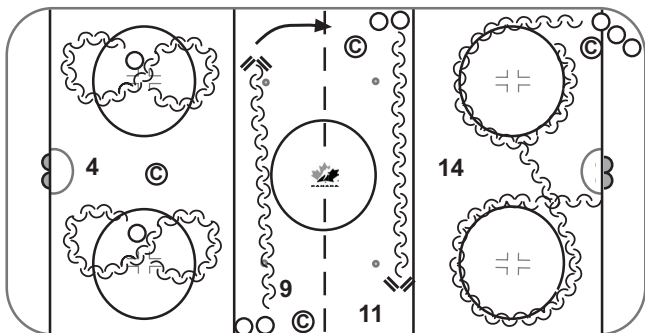

4. Figure 8's - backward - inside edge
9. Backward c-cut start
11. Two-leg backward stop
14. C-cuts - around circle - outside foot - backward

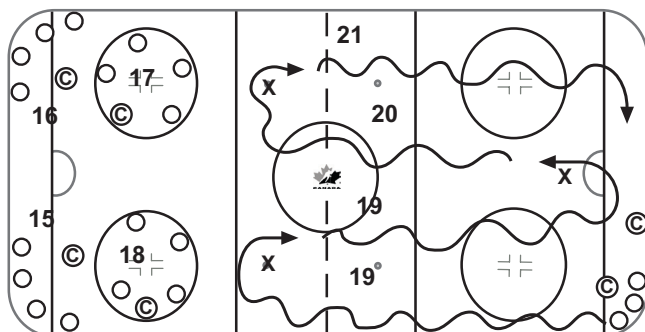

15. Side - front - side
16. Hands wide
17. Hands together
18. Narrow and wide combination
19. One leg - left and right
20. Narrow and wide combination
21. Weaving with puck